



Barcode: 5060452083131

Patent: GB2301393

Version: v101.1

# volthub™

## Safe Li-Ion battery charging

Product code: VH16-240

- » Designed to safely charge and store Li-Ion batteries
- » Passive and active technology with battery backup.
- » Weatherproof, secure and mobile, VoltHub can go anywhere.

### Product features



Standard 200mm castors



Automatic fire suppression



Crane lifting eyes



Power supply 240V



32A IP67 power inlet



RCD Protected



Safety signage



Suitable for site

### Specifications

Weight	334kg
Colour	Black grey: RAL 7021, Traffic red: RAL 3020
Suitable for	Li-Ion battery charging
Finished coating	Powder coated
Material & thickness	1.5mm steel
Quantity of keys	2 keys
How are castors fitted?	Castor plates
Ventilation	Yes
Qty of shelves as standard	16 lockers (padlockable)
Qty of power sockets	32x 240V sockets

### Dimensions - External dimensions includes protrusions

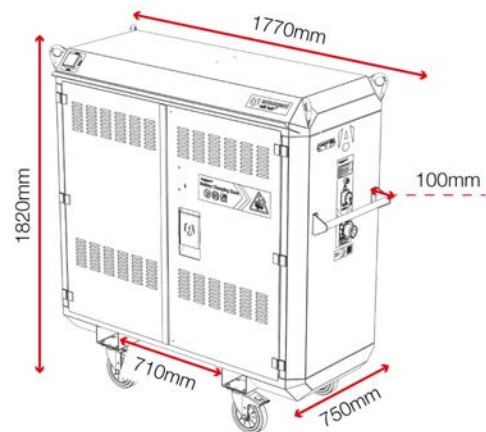

### Related products - Contact Armorgard to find out more



PowerStor FR200-P



VoltHub VH16-110

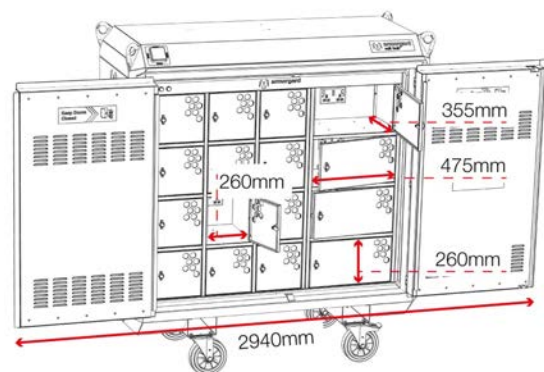

Disclaimer: all dimensions and weights are approximate